

STIHL[®]

STIHL FS 120, 250

Instruction Manual



Contents

Guide to Using this Manual	2	Special Accessories	39
Safety Precautions and Working Techniques	2	Maintenance and Repairs	40
Approved Combinations of Cutting Attachment, Deflector, Handle and Harness	12	Disposal	40
Approved Power Tool Attachments	13	EC Declaration of Conformity	41
Mounting the Bike Handle	14	Quality Certification	41
Adjusting the Throttle Cable	16		
Fitting the Carrying Ring	16		
Mounting the Deflector	16		
Mounting the Cutting Attachment	17		
Fuel	19		
Fueling	21		
Fitting the Harness	21		
Balancing the Trimmer/Brushcutter	23		
Starting / Stopping the Engine	23		
Operating Instructions	26		
Cleaning the Air Filter	26		
Adjusting the Carburetor	26		
Spark Plug	28		
Engine Running Behavior	29		
Lubricating the Gearbox	29		
Replacing the Starter Rope and Rewind Spring	30		
Storing the Machine	32		
Sharpening Metal Cutting Blades	32		
Replacing Nylon Line	33		
Replacing the Cutting Blade	34		
Maintenance and Care	35		
Main Parts	37		
Specifications	38		

Dear Customer,

Thank you for choosing a quality engineered STIHL product.

It has been built using modern production techniques and comprehensive quality assurance. Every effort has been made to ensure your satisfaction and troublefree use of the product.

Please contact your dealer or our sales company if you have any queries concerning this product.

Your



Dr. Nikolas Stihl

STIHL®

FS 120, FS 250

This instruction manual is protected by copyright. All rights reserved, especially the rights to reproduce, translate and process with electronic systems.

Guide to Using this Manual

Pictograms

The meanings of the pictograms attached to the machine are explained in this manual.

Depending on the model concerned, the following pictograms may be attached to your machine.



Fuel tank; fuel mixture of gasoline and engine oil

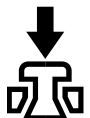

Operate decompression valve



Manual fuel pump

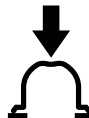

Operate manual fuel pump

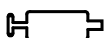

Tube of grease



Intake air: Summer operation



Intake air: Winter operation



Handle heating

Symbols in text



WARNING

Warning where there is a risk of an accident or personal injury or serious damage to property.



NOTICE

Caution where there is a risk of damaging the machine or its individual components.

Engineering improvements

STIHL's philosophy is to continually improve all of its products. For this reason we may modify the design, engineering and appearance of our products periodically.

Therefore, some changes, modifications and improvements may not be covered in this manual.

Safety Precautions and Working Techniques



Some special safety precautions must be observed to reduce the risk of personal injury when operating this power tool because of the very high speed of its cutting attachment.



It is important that you read the instruction manual before first use and keep it in a safe place for future reference. Non-observance of the instruction manual may result in serious or even fatal injury.



Observe all application local safety regulations, standards and ordinances.

If you have not used this type of power tool before: Have your dealer or other experienced user show you how to operate your unit or attend a special course in its operation.

Minors should never be allowed to use a power tool.

Keep bystanders, especially children, and animals away from the work area.

When the power tool is not in use, shut it off so that it does not endanger others. Secure it against unauthorized use.

The user is responsible for avoiding injury to third parties or damage to their property.

Do not lend or rent your power tool without the instruction manual. Be sure that anyone using it understands the information contained in this manual.

The use of noise emitting power tools may be restricted to certain times by national or local regulations.

To operate the power tool you must be rested, in good physical condition and mental health.

If you have any condition that might be aggravated by strenuous work, check with your doctor before operating a power tool.

Persons with pacemakers only: The ignition system of your power tool produces an electromagnetic field of a very low intensity. This field may interfere with some pacemakers. STIHL recommends that persons with pacemakers consult their physician and the pacemaker manufacturer to reduce any health risk.

Do not operate the power tool if you are under the influence of any substance (drugs, alcohol) which might impair vision, dexterity or judgment.

Depending on the cutting attachment fitted, use your power tool only for cutting grass, wild growth, shrubs, scrub, bushes, small diameter trees and similar materials.

Do not use your power tool for any other purpose because of the **increased risk of accidents**.

Only use cutting attachments and accessories that are explicitly approved for this power tool model by STIHL or are technically identical. If you have any questions in this respect, consult a

servicing dealer. Use only high quality parts and accessories in order to avoid the risk of accidents and damage to the machine.

STIHL recommends the use of original STIHL replacement parts. They are specifically designed to match the product and meet your performance requirements.

Never attempt to modify your unit in any way since this may increase the risk of personal injury. STIHL excludes all liability for personal injury and damage to property caused while using unauthorized attachments.

Do not use a pressure washer to clean the unit. The solid jet of water may damage parts of the unit.

The deflector on this power tool cannot protect the operator from all objects thrown by the cutting attachment (stones, glass, wire, etc.). Such objects may ricochet and then hit the operator.

Clothing and Equipment

Wear proper protective clothing and equipment.



Clothing must be sturdy but allow complete freedom of movement. Wear snug-fitting clothing, an overall and jacket combination, do not wear a work coat.



Avoid clothing that could get caught on branches or brush or moving parts of the machine. Do not wear a scarf, necktie or jewelry. Tie up and confine long hair (e.g. with a hair net, cap, hard hat, etc.).



Wear steel-toed safety boots with non-slip soles.

Sturdy shoes with non-slip soles may be worn as an alternative only when using mowing heads.



Wear a safety hard hat for thinning operations, when working in high scrub and where there is a danger of head injuries from falling objects. To reduce the risk of injury from thrown objects, always wear a face shield and safety glasses.

A face shield alone does not provide adequate eye protection.

Wear hearing protection, e.g. earplugs or ear muffs.



Wear heavy-duty gloves.

STIHL offers a comprehensive range of personal protective clothing and equipment.

Transporting the Power Tool

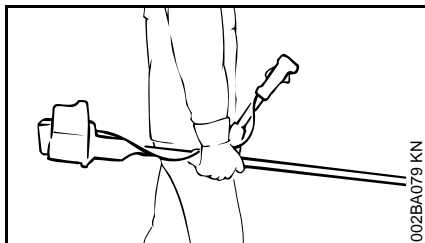
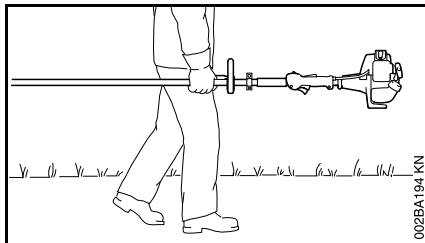

Always turn off the engine.

Carry the unit hanging from the shoulder strap or properly balanced by the drive tube. Fit transport guard on metal cutting attachments to avoid the risk of injury from blade contact

In vehicles: Properly secure your power tool to prevent turnover, fuel spillage and damage.

Fueling



Gasoline is an extremely flammable fuel. Keep clear of naked flames. Do not spill any fuel – do not smoke.

Always shut off the engine before refueling.

Do not fuel a hot engine – **fuel may spill and cause a fire.**

Open the fuel cap carefully to allow any pressure build-up in the tank to release slowly and avoid fuel spillage.

Fuel your power tool only in well-ventilated areas. If you spill fuel, wipe the machine immediately – if fuel gets on your clothing, change immediately.

Your power tool comes standard with either a screw-type or bayonet-type fuel cap.



After fueling, tighten down the screw-type fuel cap as securely as possible.



Insert the fuel cap with hinged grip (bayonet-type cap) correctly in the opening, turn it clockwise as far as stop and fold the grip down.

This reduces the risk of unit vibrations causing the fuel cap to loosen or come off and spill quantities of fuel.

To reduce the risk of serious or fatal burn injuries, check for fuel leakage. If fuel leakage is found, do not start or run the engine until leak is fixed.

Before Starting

Check that your power tool is properly assembled and in good condition – refer to appropriate chapters in the instruction manual.

- Use only an approved combination of cutting attachment, deflector, handle and harness. All parts must be assembled properly and securely.
- Slide control / stop switch must move easily to **STOP** or **0**.
- Smooth action of throttle trigger lockout (if fitted) and throttle trigger – the throttle trigger must return automatically to the idle position.
- Check that the spark plug boot is secure – a loose boot may cause arcing that could ignite combustible fumes **and cause a fire**.
- Check cutting tool or attachment for correct and secure assembly and good condition.
- Check protective devices (e.g. deflector for cutting attachment, rider plate) for damage or wear. Always replace damaged parts. Do not operate your machine with a damaged deflector or worn rider plate (lettering and arrows no longer legible).
- Never attempt to modify the controls or safety devices in any way.

- Keep the handles dry and clean – free from oil and dirt – for safe control of the power tool.
- Adjust the harness and handle(s) to suit your height and reach. See chapters on "Fitting the Harness" and "Balancing the Trimmer/Brushcutter".

To reduce the risk of personal injury, do not operate your power tool if it is damaged or not properly assembled.

If you use a shoulder strap or full harness: Practice removing and putting down the power tool as you would in an emergency. To avoid damage, do not throw the power tool to the ground when practicing.

Start the engine.

Start the engine at least 3 meters from the fueling spot, outdoors only.

Place the unit on firm ground in an open area. Make sure you have good balance and secure footing. Hold the unit securely. The cutting attachment must be clear of the ground and all other obstructions because it may begin to run when the engine starts.

Your power tool is a one-person unit. **To reduce the risk of injury** from thrown objects, do not allow other persons within a radius of 15 meters of your own position – even when starting.



To reduce the risk of injury, avoid contact with the cutting attachment.



Do not drop start the power tool – start the engine as described in the instruction manual. Note that the cutting attachment continues to run for a short period after you let go of the throttle trigger – **flywheel effect**.

Check idle speed setting: The cutting attachment must not rotate when the engine is idling with the throttle trigger released.

To reduce the risk of fire, keep hot exhaust gases and hot muffler away from easily combustible materials (e.g. wood chips, bark, dry grass, fuel).

Holding and Controlling the Unit

Always hold the power tool firmly with both hands on the handles.

Make sure you always have good balance and secure footing.

Models with bike handle

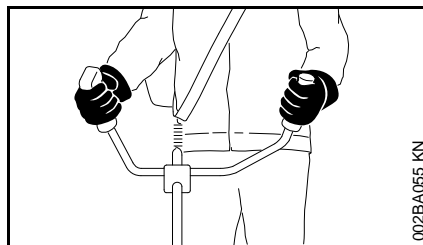

Right handle on control handle, left hand on left handle.

Models with loop handle

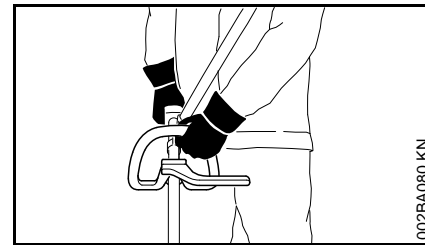

On models with a loop handle and barrier bar, left hand on loop handle, right hand on control handle, even if you are left-handed.

During Operation

Make sure you always have good balance and secure footing.

In the event of impending danger or in an emergency, switch off the engine immediately by moving the slide control / stop switch to **STOP** or **0**.

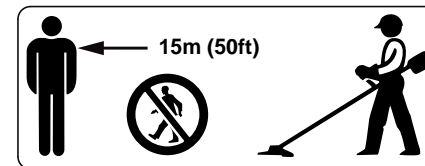

The cutting attachment may catch and fling objects a great distance and cause injury - therefore, do not allow any other persons within a radius of 15 meters of your own position. **To reduce the risk of damage to property**, also maintain this distance from other objects (vehicles, windows). Even maintaining a distance of 15 meters or more cannot exclude the potential danger.

The correct engine idle speed is important to ensure that the cutting attachment stops rotating when you let go of the throttle trigger.

Check and correct the idle speed setting regularly. If the cutting attachment continues to rotate when the engine is idling, have the machine checked by your servicing dealer. STIHL recommends a STIHL servicing dealer.

Take special care in slippery conditions, on slopes or uneven ground.

Watch out for obstacles: Roots, tree stumps or holes which **could cause you to trip or stumble**.

Always stand on the ground while working, never on a ladder, work platform or any other insecure support.

Be particularly alert and cautious when wearing hearing protection because your ability to hear warnings (shouts, alarms, etc.) is restricted.

To reduce the risk of accidents, take a break in good time to avoid tiredness or exhaustion.

Work calmly and carefully – in daylight conditions and only when visibility is good. Stay alert so as not to endanger others.



Your power tool produces toxic exhaust fumes as soon as the engine is running. These fumes may be colorless and odorless and contain unburned hydrocarbons and benzol. Never run the engine indoors or in poorly ventilated locations, even if your model is equipped with a catalytic converter.

To reduce the risk of serious or fatal injury from breathing toxic fumes, ensure proper ventilation when working in trenches, hollows or other confined locations.

To reduce the risk of accidents, stop work immediately in the event of nausea, headache, visual disturbances (e.g. reduced field of vision), problems with hearing, dizziness, deterioration in ability to concentrate. Apart from other possibilities, these symptoms may be caused by an excessively high concentration of exhaust gases in the work area.

Operate your power tool so that it produces a minimum of noise and emissions – do not run the engine unnecessarily, accelerate the engine only when working.

To reduce the risk of fire, do not smoke while operating or standing near your power tool. Note that combustible fuel vapor may escape from the fuel system.

The dusts, vapor and smoke produced during operation may be dangerous to health. If the work area is very dusty or smoky, wear a respirator.

If your power tool is subjected to unusually high loads for which it was not designed (e.g. heavy impact or a fall), always check that it is in good condition before continuing work – see also "Before Starting".

Check the fuel system in particular for leaks and make sure the safety devices are working properly. Do not continue operating your power tool if it is damaged. In case of doubt, have the unit checked by your servicing dealer.

Do not operate your power tool in the starting throttle position – engine speed cannot be controlled in this position.



To reduce the risk of injury from thrown objects, never operate the unit without the proper deflector for the type of cutting attachment being used.



Inspect the work area: Stones, pieces of metal or other solid objects may be thrown more than 15 meters and **cause personal injury** or damage the cutting attachment and property (e.g. parked vehicles, windows).

Special care must be taken when working in difficult, over-grown terrain.

When cutting high scrub, under bushes and hedges: Keep cutting attachment at a minimum height of 15 cm to avoid harming small animals.

Always shut off the engine before leaving the unit unattended.

Check the cutting attachment at regular short intervals during operation or immediately if there is a noticeable change in cutting behavior:

- Turn off the engine. Hold the unit firmly and wait for the cutting attachment to come to a standstill.
- Check condition and tightness, look for cracks.
- Check sharpness.
- Replace damaged or dull cutting attachments immediately, even if they have only superficial cracks.

Clean grass and plant residue off the cutting attachment mounting at regular intervals – remove any build up of material from the cutting attachment and deflector.

To **reduce the risk of injury**, shut off the engine before replacing the cutting attachment.

Do not continue using or attempt to repair damaged or cracked cutting attachments by welding, straightening or modifying the shape (out of balance).

This may cause parts of the cutting attachment to come off and hit the operator or bystanders at high speed and **result in serious or fatal injuries**.

When using mowing heads

Equip the deflector with the additional components specified in the instruction manual.

Use only the deflector with properly mounted line limiting blade to ensure the mowing lines are automatically trimmed to the approved length.

To **reduce the risk of injury**, always turn off the engine before adjusting the nylon line of manually adjustable mowing heads

Using the unit with over-long nylon cutting lines reduces the motor's operating speed. The clutch then slips continuously and this causes overheating and damage to important components (e.g. clutch, polymer housing components) – **and this can increase the risk of injury** from the cutting attachment rotating while the engine is idling.

Using metal cutting attachments

STIHL recommends the use of original STIHL metal cutting attachments. They are specifically designed to match your model and meet your performance requirements.

Metal cutting attachments rotate at very high speed. The forces that occur act on the machine, the attachment and the material being cut.

Sharpen metal cutting attachments regularly as specified.

Unevenly sharpened metal cutting attachments cause out-of-balance which can impose extremely high loads on the machine and increase the **risk of breakage**.

Dull or improperly sharpened cutting edges can put a higher load on the cutting attachment and increase the **risk of injury** from cracked or broken parts.

Inspect metal cutting attachments for cracks or warping after every contact with hard objects (e.g. stones, rocks, pieces of metal). To **reduce the risk of injury**, remove burrs and other visible build-ups of material (use a file) because they may become detached and be thrown at high speed during operation.

To reduce the above-mentioned risks when using a metal cutting attachment, never use a metal cutting attachment with a diameter larger than specified. It must not be too heavy. It must be manufactured from materials of adequate quality and its geometry must be correct (shape, thickness).

To **reduce the risk of injury**, a metal cutting attachment not manufactured by STIHL must not be heavier, thicker, have a different shape or a diameter larger than the largest metal cutting attachment approved by STIHL for this power tool model.

Vibrations

Prolonged use of the power tool may result in vibration-induced circulation problems in the hands (whitefinger disease).

No general recommendation can be given for the length of usage because it depends on several factors.

The period of usage is prolonged by:

- Hand protection (wearing warm gloves)
- Work breaks

The period of usage is shortened by:

- Any personal tendency to suffer from poor circulation (symptoms: frequently cold fingers, tingling sensations).
- Low outside temperatures.
- The force with which the handles are held (a tight grip restricts circulation).

Continual and regular users should monitor closely the condition of their hands and fingers. If any of the above symptoms appear (e.g. tingling sensation in fingers), seek medical advice.

Maintenance and Repairs

Service the machine regularly. Do not attempt any maintenance or repair work not described in the instruction manual. Have all other work performed by a servicing dealer.

STIHL recommends that you have servicing and repair work carried out exclusively by an authorized STIHL servicing dealer. STIHL dealers are regularly given the opportunity to attend training courses and are supplied with the necessary technical information.

Only use high-quality replacement parts in order to avoid the risk of accidents and damage to the machine. If you have any questions in this respect, consult a servicing dealer.

STIHL recommends the use of genuine STIHL replacement parts. They are specifically designed to match your model and meet your performance requirements.

To reduce the risk of injury, **always shut off the engine** before carrying out any maintenance or repairs or cleaning the machine. – Exception: Carburetor and idle speed adjustments.

Do not turn the engine over on the starter with the spark plug boot or spark plug removed unless the slide control / stop switch is on **STOP** or **0** since there is otherwise a **risk of fire** from uncontained sparking.

To reduce the **risk of fire**, do not service or store your machine near open flames.

Check the fuel filler cap for leaks at regular intervals.

Use only a spark plug of the type approved by STIHL and make sure it is in good condition – see "Specifications".

Inspect the ignition lead (insulation in good condition, secure connection).

Check the condition of the muffler.

To reduce the **risk of fire and damage to hearing**, do not operate your machine if the muffler is damaged or missing.

Do not touch a hot muffler since **burn injury** will result.

Vibration behavior is influenced by the condition of the AV elements – check the AV elements at regular intervals.

Symbols on Deflectors

An **arrow** on the deflector shows the correct direction of rotation of the cutting attachments.

Some of the following symbols are applied to the outside of the deflector to indicate the approved combination of cutting attachment and deflector.



Deflector may be used with mowing heads. Not approved for use with brush knives, shredder blades or circular saw blades.



Deflector may be used with grass cutting blades.

Harness / Strap

The harness is included in the scope of supply or available as a special accessory.

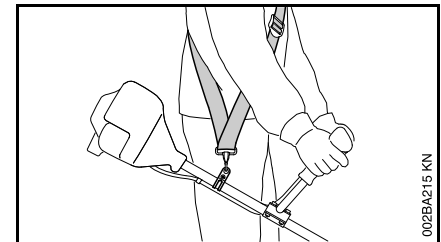

- Use a shoulder strap.
- With the engine running, attach the machine to the shoulder strap.

Grass cutting blades and brush knives must always be used in combination with a shoulder strap.

Circular saw blades must always be used in combination with a full harness with a quick-release system.

Mowing Head with Nylon Line

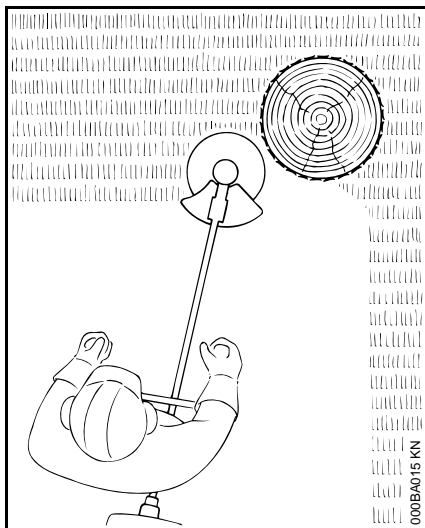

Nylon line achieves a soft cut for edging and trimming around trees, fence posts, etc. – less risk of damaging tree bark.

The mowing head comes with an instruction leaflet. Refill the mowing head with nylon line as described in the instruction leaflet.

! WARNING

To reduce the risk of serious injury, never use wire or metal-reinforced line in place of the nylon line.

STIHL FixCut

Check the wear limit marks!

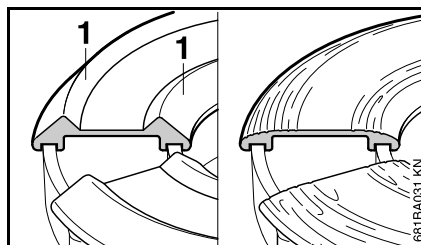

- If the raised moldings (1) on the base of the attachment are worn as shown in the illustration (above right), do not continue using the mowing head. Install a new one. There is otherwise a **risk of injury** from thrown parts of the head.

STIHL Polycut Mowing Head with Polymer Blades

For mowing unobstructed edges of meadows (without posts, fences, trees or similar obstacles).

Check the wear limit marks!

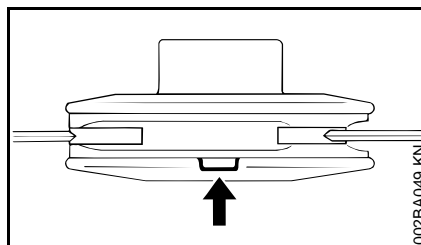

If one of the wear limit marks on the Polycut mowing head is worn through (arrow): Do not continue using the mowing head. Install a new one. There is otherwise a **risk of injury** from thrown parts of the head.

It is important to follow the maintenance instructions for the PolyCut mowing head.

The PolyCut can also be equipped with mowing line in place of the polymer blades.

The mowing head comes with instruction leaflets. Equip the mowing head with polymers blades or nylon line as described in the instruction leaflets.

! WARNING

Never use wire in place of the nylon mowing line – **risk of injury**.

Risk of Kickout (Blade Thrust) with Metal Cutting Attachments

When using metal cutting attachments (grass cutting blade, brush knife, circular saw blade) there is a risk of kickout when the rotating blade comes into contact with a solid object such as a tree trunk, branch, tree stump, rock or similar. The machine is thrown to the right or to the rear – opposite to the attachment's direction of rotation.

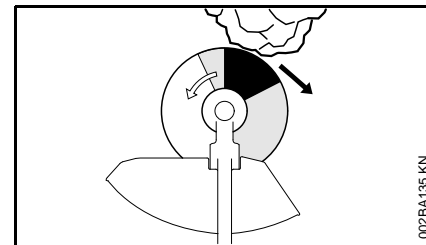

The **risk of kickout is greatest** when the **black area** of the rotating cutting attachment comes into contact with a solid object.

Grass Cutting Blade

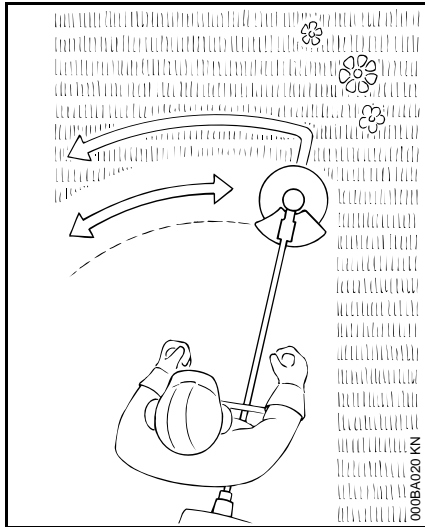

Use for grass and weeds only – sweep the brushcutter in an arc like a scythe.

! WARNING

Improper use may damage the grass cutting blade – **risk of injury** from thrown parts.

Resharpener the grass cutting blade according to instructions when it has dulled noticeably.

Brush Knife

For cutting matted grass, wild growth and scrub and thinning young stands with a stem diameter of no more than 2 cm – do not cut thicker stems – **risk of accidents.**

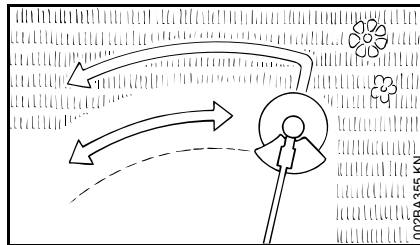

Use the brushcutter like a scythe (sweep it to the right and left) at ground level when cutting grass and thinning young stands.

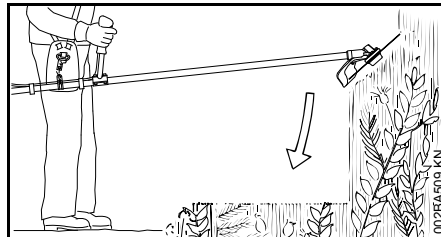

To cut wild growth and scrub, lower the brush knife down onto the growth to achieve a shredding effect – always keep the cutting attachment below hip level during this process.

Exercise extreme caution when using this method of cutting. The higher the cutting attachment is off the ground, the greater the risk of injury from cuttings being thrown sideways.

Warning! Improper use of a brush knife may cause it to crack, chip or shatter – **risk of injury** from thrown parts.

To reduce the risk of injury it is essential to take the following precautions:

- Avoid contact with stones, rocks, pieces of metal and other solid foreign objects.
- Never cut wood or shrubs with a stem diameter of more than 2 cm – use a circular saw blade for such work.
- Inspect the brush knife at regular short intervals for signs of damage. Do not continue working with a damaged brush knife.
- Resharpener the brush knife regularly and whenever it has dulled noticeably, and have it balanced if necessary (STIHL recommends a STIHL servicing dealer).

Circular Saw Blade

For cutting shrubs and trees:

Up to a stem diameter of 4 cm when used on brushcutters.

Up to a stem diameter of 7 cm when used on clearing saws.

Before starting the cut, accelerate the engine up to full throttle. Perform cut with uniform pressure.

Use circular saw blades only with a matching limit stop of the correct diameter.

! WARNING

To reduce the risk of blade damage, avoid contact with stones and the ground. Resharpener the blade properly in

good time – dull teeth may result in the blade cracking and shattering and causing serious injury.

When felling, maintain a distance of at least two tree lengths from the next felling site.

Risk of kickout

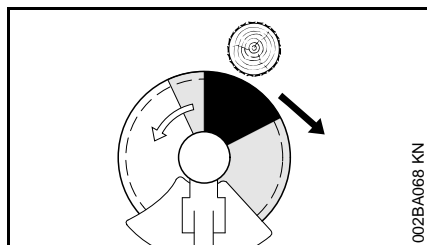







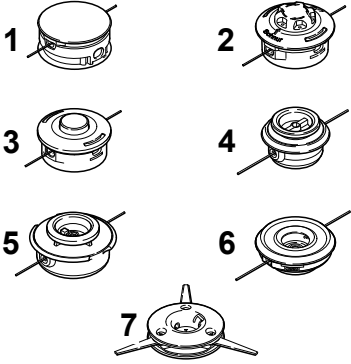
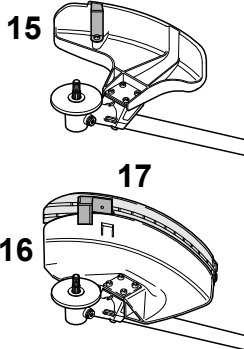
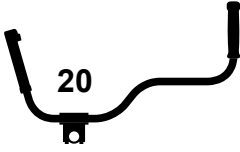
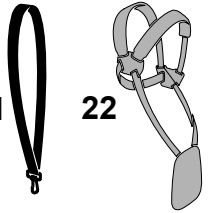
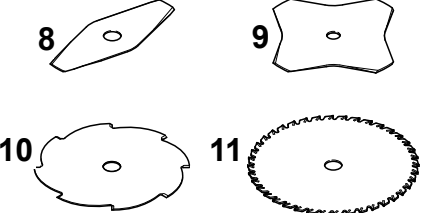
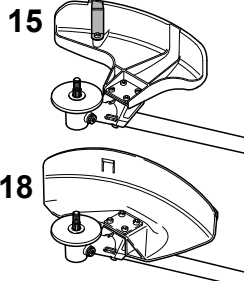
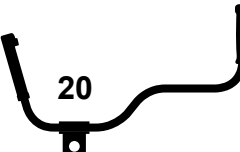
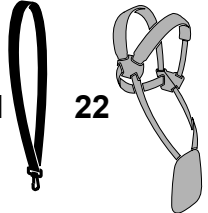

The risk of kickout is highest in the black area of the blade: Do not use this area of the circular saw blade for cutting.

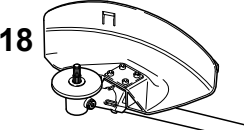
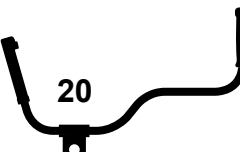
There is also a risk of kickout when using the lighter shaded areas of the blade: These areas of the blade should only be used by experienced operators with specialized training.

STIHL recommends that you use the non-shaded area of the circular saw blade. Always start the cut with this area of the blade.

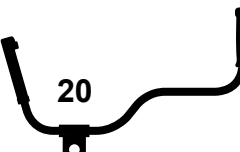
Approved Combinations of Cutting Attachment, Deflector, Handle and Harness

Cutting Attachment	Deflector	Handle	Harness
 <p>1, 2, 3, 4, 5, 6, 7</p>	 <p>15, 16, 17</p>	 <p>20</p>	 <p>21, 22</p>
 <p>8, 9, 10, 11</p>	 <p>15, 18</p>	 <p>20</p>	 <p>21, 22</p>
 <p>12</p>	 <p>18</p>	 <p>20</p>	 <p>21, 22</p>
 <p>13, 14</p>	 <p>19</p>	 <p>20</p>	 <p>23</p>

681BA204 KN

Approved Combinations

Select correct combination from the table according to the cutting attachment you intend to use.

WARNING

For safety reasons only the cutting attachments, deflectors, handles and harnesses shown in each row of the table may be used together. No other combinations are permitted because of the **risk of accidents**.

Cutting Attachments

Mowing heads

- 1 STIHL SuperCut 20-2
- 2 STIHL AutoCut 25-2
- 3 STIHL AutoCut 30-2
- 4 STIHL TrimCut 30-2
- 5 STIHL TrimCut 31-2
- 6 STIHL FixCut 25-2
- 7 STIHL PolyCut 20-3

Metal cutting attachments

- 8 Grass cutting blade 230-2
- 9 Grass cutting blade 230-4
- 10 Grass cutting blade 230-8
- 11 Grass cutting blade 250-40 Spezial
- 12 Brush knife 250-3
- 13 Scratcher tooth circular saw blade 200
- 14 Chisel tooth circular saw blade 200

WARNING

Non-metal grass cutting blades, brush knives and circular saw blades are not approved.

Deflectors

- 15 Deflector for mowing heads and grass cutting blades
- 16 Deflector **with**
- 17 Skirt and blade for all mowing heads
- 18 Deflector **without** skirt and blade for all metal mowing attachments and brush knife
- 19 Limit stop for circular saw blades

Handles

- 20 Bike handle

Harnesses

- 21 Shoulder strap must be used
- 22 Full harness may be used
- 23 Full harness must be used

Approved Power Tool Attachments

The following STIHL attachment may be mounted to the basic power tool:

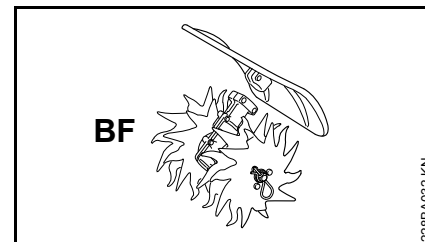

Attachment	Application
BF	Pick tines

Mounting the Bike Handle

Mounting Bike Handle with Swiveling Handle Support

The machine is supplied with the swivelling handle support already mounted on the shaft. To mount the handlebar it is necessary to remove the clamp moldings.

Removing the Clamp Moldings

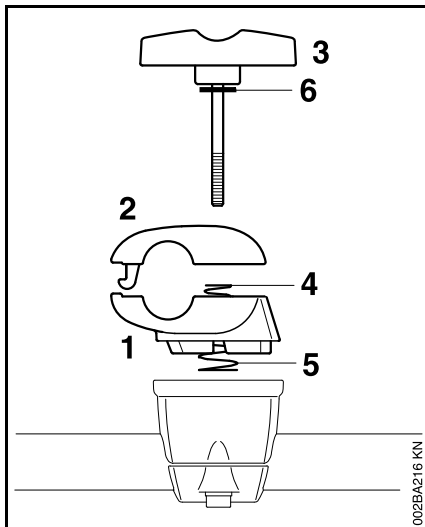

- Hold the lower clamp (1) and upper clamp (2) firmly together.
- Release the wing screw (3) – the clamps are loose once the wing screw has been released. They are pushed apart by the two springs (4 and 5).

- Pull out the wing screw – the washer (6) remains on the wing screw.
- Separate the clamp moldings – the springs (4 and 5) remain in the lower clamp.

Securing the handlebar

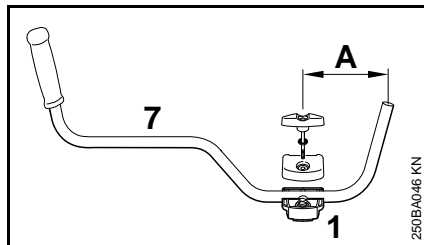

- Place the handlebar (7) in the lower clamp (1) so that distance A is no more than 15 cm (6 in).
- Place the upper clamp in position and hold both clamp moldings together.
- Push the wing screw through the two clamps as far as stop – hold all parts together and secure them.

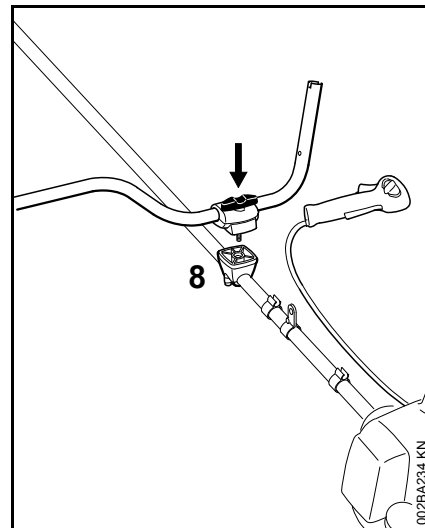

- Place the secured assembly on the handle support (8) with the wing screw at the side nearest the engine.
- Push the wing screw into the handle support as far as stop and then screw it down – but do not finally tighten yet.
- Line up the handlebar at a right angle to the drive tube – check distance A again.
- Tighten down the wing screw firmly.

Mounting the Control Handle

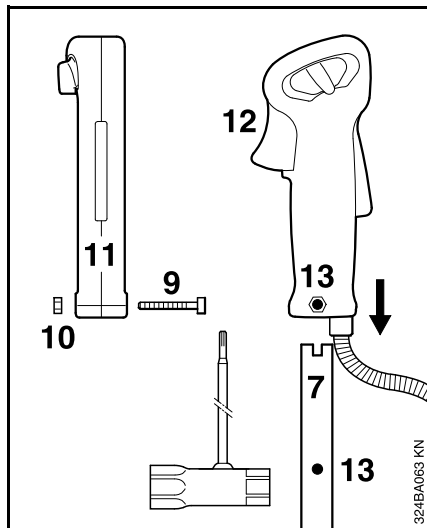

- Take out the screw (9) – the nut (10) remains in the control handle (11).
- Push the control handle onto the end of the handlebar (7) until the holes (13) line up – the throttle trigger (12) must point towards the gearhead.
- Insert the screw (9) and tighten it down firmly.

Fitting the Throttle Cable



NOTICE

Do not kink the throttle cable or lay it in tight radii – make sure the throttle trigger moves freely.

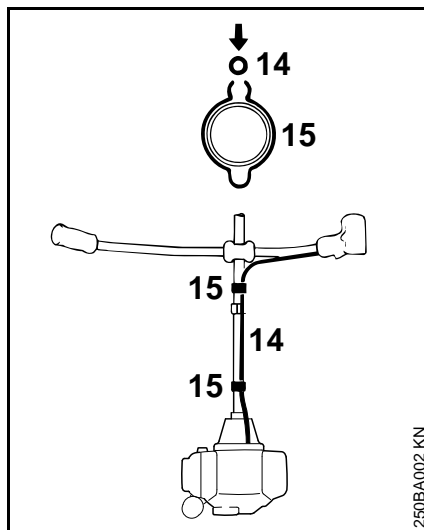

- Push the throttle cable (14) into the retainers (15).

Adjusting the Throttle Cable

- Check adjustment of throttle cable – see chapter on "Adjusting the Throttle Cable".

Swiveling the Handlebar

Transport position

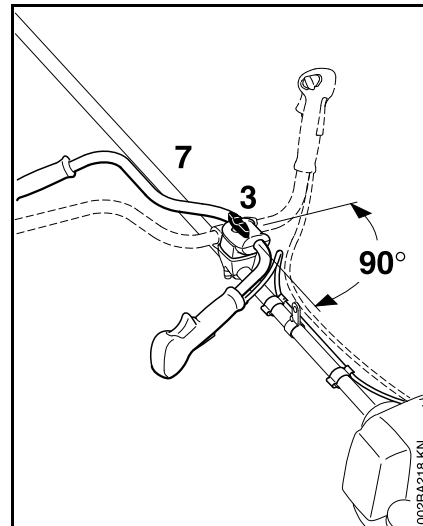

- Loosen the wing screw (3) and unscrew it until the handlebar (7) can be turned clockwise.
- Turn the handlebar 90° and then swing the handles down.
- Tighten down the wing screw (3) firmly.

Working position

- Reverse the sequence described above to swing the handles up and turn the handlebar counterclockwise.

Adjusting the Throttle Cable

A properly adjusted throttle cable is the precondition for correct operation in the full throttle, starting throttle and idle positions.

Adjust the throttle cable only after the unit is fully assembled – the control handle must be in the normal operating position.

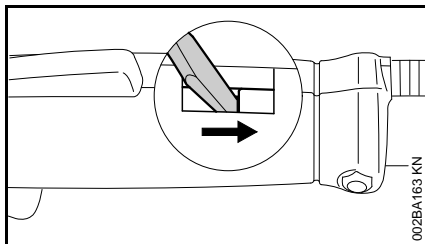

002BA163 KN

- Use a suitable tool to push the slide to the end of the slot (see illustration).

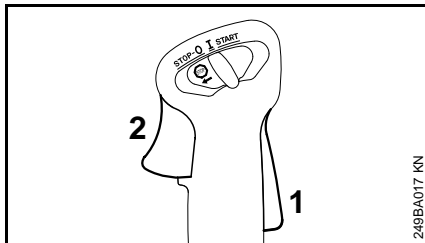

249BA017 KN

- Press down the throttle trigger lockout (1) and squeeze the throttle trigger (2) (full throttle) – this sets the throttle cable correctly.

Fitting the Carrying Ring

The carrying ring comes standard with the machine or is available as a special accessory.

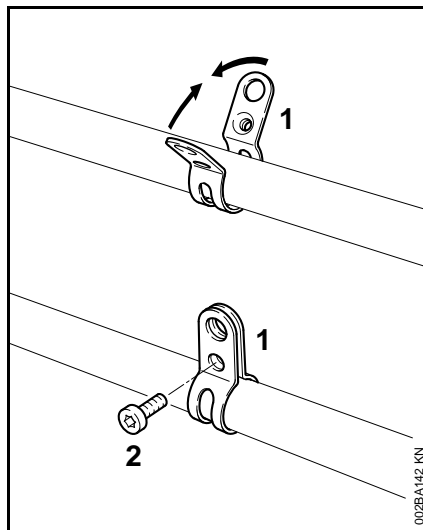

002BA142 KN

For position of carrying ring see "Main Parts".

- Place the clamp (1) against the drive tube **with the tapped hole on the left** (viewed from engine).
- Squeeze the two ends of the clamp together and hold in that position.
- Insert the M6x14 screw (2).
- Line up the carrying ring.
- Tighten down the screw firmly.

Mounting the Deflector

Mounting the Deflector

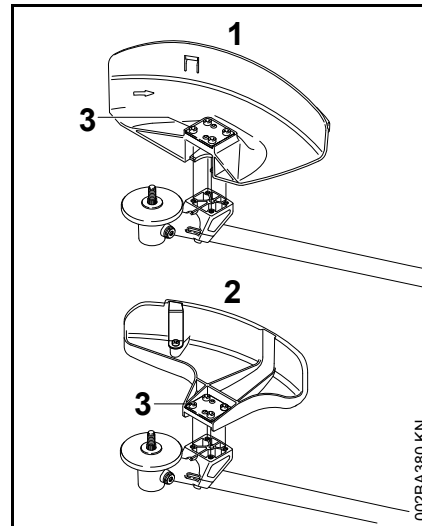

002BA380 KN

- 1 Deflector for mowing attachments
- 2 Deflector for mowing heads and grass cutting blades

Deflectors (1) and (2) are both mounted to the gearbox in the same way.

- Place the deflector on the gearbox flange.
- Insert the screws (3) and tighten them down firmly.

Fitting the Skirt and Blade

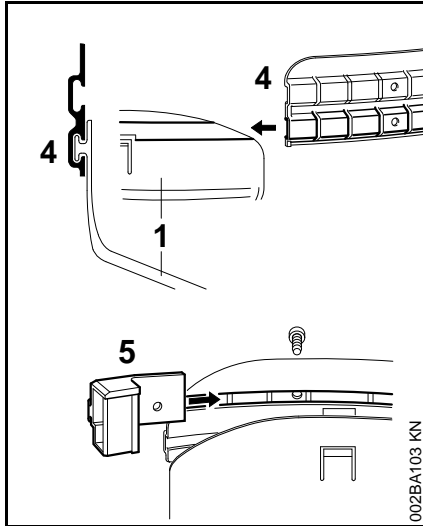

! WARNING

These parts must be fitted to the deflector (1) when you use a mowing head.

- Slide the lower guide slot of the skirt (4) onto the deflector (1) – it must snap into position.
- Push the blade (5) into the upper guide slot on the skirt and line it up with the first hole.
- Insert the screw and tighten it down firmly.

Mounting the Limit Stop

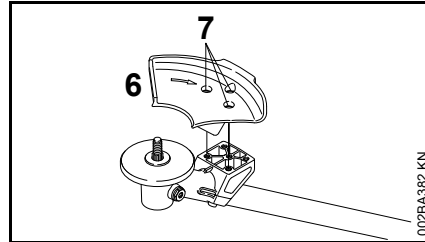

! WARNING

Always fit the limit stop (6) when you use a circular saw blade.

- Position the limit stop (6) on the gearbox flange.
- Insert the screws (7) and tighten them down firmly.

Mounting the Cutting Attachment

Preparations

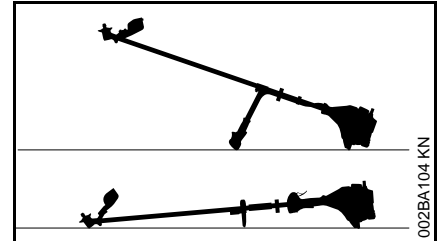

- Lay your brushcutter on its back so that the cutting attachment mounting face is facing up.

Block the shaft.

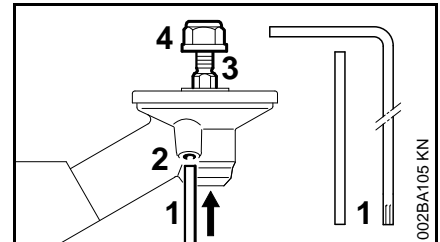

- Insert the stop pin (1) or screwdriver – come standard with machine or are available as special accessories – in the hole (2) in the gearbox as far as stop, and apply slight pressure.
- Rotate the nut (4) or cutting attachment on the shaft (3) until the stop pin slips into position and blocks the shaft.

Removing the Mounting Hardware

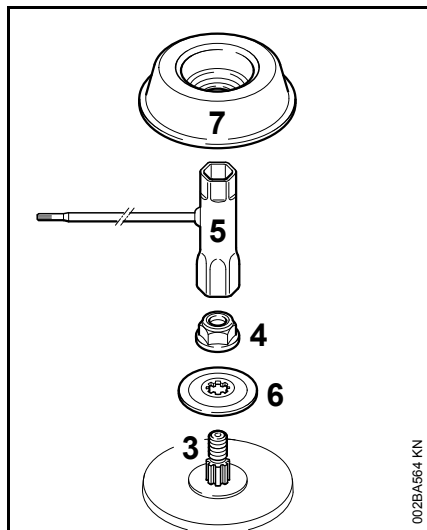

- Use the combination wrench (5) – comes standard with the machine or is available as special accessory – to unscrew the nut (4) clockwise (left-hand thread) from the shaft (3).
- Pull the thrust washer (6) off the shaft (3).

The rider plate (7) is in the parts kit supplied with the machine.

- Go to "Mounting the Mowing Head" or "Mounting the Metal Cutting Attachment".

Mounting the mowing head

Keep the instruction sheet for the mowing head in a safe place.

STIHL SuperCut 20-2,
STIHL AutoCut 25-2,
STIHL AutoCut 30-2,
STIHL TrimCut 31-2,
STIHL FixCut 25-2,
STIHL PolyCut 20-3

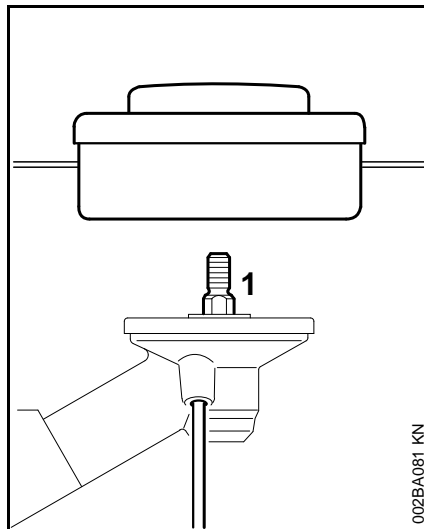

- Screw the mowing head counterclockwise on to the shaft (1) as far as stop.
- Block the shaft.
- Tighten down the mowing head.



Remove the tool used to block the shaft.

Removing the mowing head

STIHL SuperCut 20-2,
STIHL AutoCut 25-2,
STIHL AutoCut 30-2,

STIHL TrimCut 31-2,
STIHL FixCut 25-2,
STIHL PolyCut 20-3

- Block the shaft.
- Unscrew the mowing head clockwise.

Mounting Metal Cutting Attachments

WARNING

Wear protective gloves to reduce the risk of direct contact with the sharp cutting edges.

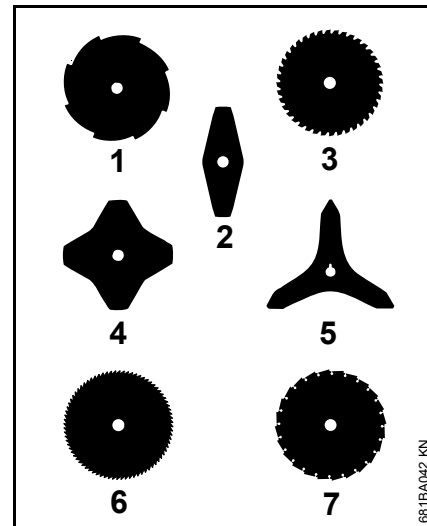

The skirt and line limiting blade are not required on the mowing attachment deflector for grass cutting blades 230-2 (2), 230-4 (4), 230-8 (1), 250-40 Spezial (3) or the brush knife (5) – see "Mounting the Deflector".

! WARNING

Fit the appropriate **limit stop** for circular saw blades 200 (6, 7) – see "Mounting the deflector".

Lay your brushcutter on its back with the cutting attachment mounting face pointing up: The cutting edges of (2), (4) and (5) may point in either direction. The cutting edges of (1), (3), (6) and (7) must point clockwise.

Direction of rotation is indicated by an arrow on the inside of the mowing attachment deflector or limit stop.

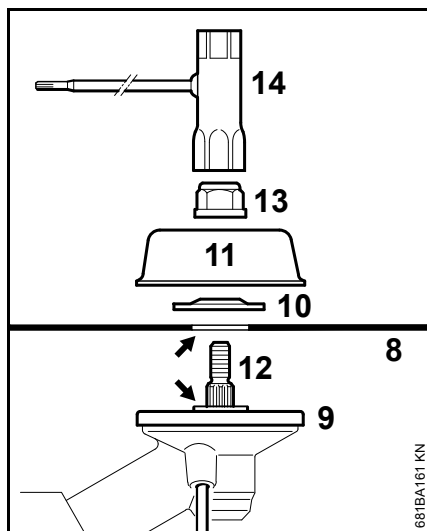

- Place the cutting attachment (8) on the thrust plate (9).

! WARNING

Collar (see arrow) must engage the cutting attachment's mounting hole.

- Fit the thrust washer (10) and rider plate (11) on the shaft (12).
- Block the shaft.
- Use the combination wrench (14) to screw the mounting nut (13) on to the output shaft counterclockwise and tighten it down firmly.

⚙ NOTICE

Remove the tool used to block the shaft.

Removing the Metal Cutting Attachment

! WARNING

Wear protective gloves to reduce the risk of direct contact with the sharp cutting edges.

- Block the shaft.
- Unscrew the mounting nut clockwise.
- Take the parts off the shaft – do **not** remove the thrust plate (9).

! WARNING

If the mounting nut turns too freely, fit a new one.

Fuel

The engine requires a mixture of gasoline and engine oil.

! WARNING

Avoid direct skin contact with and breathing in of gasoline fumes.

STIHL MotoMix

STIHL recommends using STIHL MotoMix. This pre-blended fuel is free of benzene and lead, stands out because of a high octane rating, and always provides the proper mixing ratio.

STIHL MotoMix is blended with STIHL HP Ultra two-stroke engine oil for maximum engine life.

MotoMix is not available in all markets.

Mixing fuel

⚙ NOTICE

Unsuitable fuels or a mixing ratio that deviates from the specification can lead to severe engine damage. The engine, seals, fuel lines and fuel tank may be damaged if poor quality gasoline or engine oil is used.

Gasoline

Use only **high-quality gasoline** with an octane rating of at least 90 ROC – leaded or unleaded.

Unleaded gasoline must be used in machines equipped with a catalytic converter.



NOTICE

Using multiple tankfuls of leaded gasoline can substantially reduce the effectiveness of the catalytic converter.

Gasoline with an alcohol component exceeding 10% can cause impaired engine performance in engines with manually adjustable carburetors and thus should not be used in these engines.

Engines with M-Tronic deliver full engine performance using gasoline with an alcohol component of up to 25% (E25).

Engine oil

Use only high-quality two-stroke engine oil – ideally **STIHL HP, HP Super or HP Ultra two-stroke engine oil, as they are specially engineered for STIHL engines. HP Ultra ensures maximum performance and engine life.**

The engine oils are not available in all markets.

Only **STIHL two-cycle engine oil 1:50** may be used to produce the fuel mixture for machines with a catalytic converter.

Mixing ratio

for STIHL two-cycle engine oil 1:50;
1:50 = 1 part oil + 50 parts gasoline

Examples

Quantity of gasoline	STIHL two-cycle engine oil 1:50	
Liters	Liters	(ml)
1	0.02	(20)
5	0.10	(100)
10	0.20	(200)
15	0.30	(300)
20	0.40	(400)
25	0.50	(500)

- Pour oil into an approved safety fuel canister first, then add gasoline and mix thoroughly

Storing fuel mixture

Store in approved safety fuel canisters only in a dry, cool and secure place protected against light and sunlight.

Fuel mixture ages – mix only as much as needed for a few weeks. Do not store fuel mixture for longer than three months. The fuel mixture can become unusable faster if exposed to light, sunlight or low or high temperatures.

- Shake the canister containing the fuel mixture thoroughly before refueling



WARNING

Pressure can build up inside the canister – open carefully.

- The fuel tank and the canister in which fuel mixture is stored should be cleaned thoroughly from time to time

Residual fuel and the liquid used for cleaning must be disposed of in accordance with regulations and without harming the environment!

Fueling



Preparations

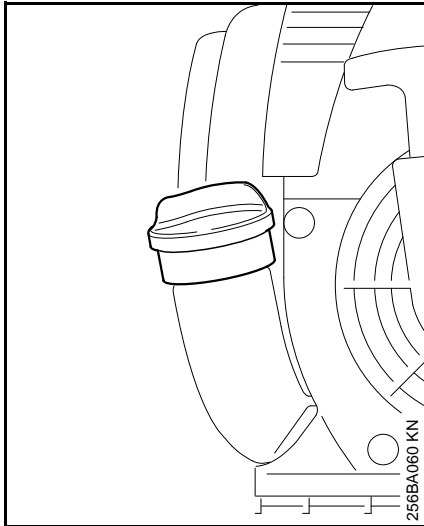

- Before fueling, clean the filler cap and the area around it to ensure that no dirt falls into the tank.
- Position the machine so that the filler cap is facing up.

Filling Up with Fuel

Take care not to spill fuel while fueling and do not overfill the tank. STIHL recommends you use the STIHL filler nozzle for fuel (special accessory).

- Open the filler cap.
- Fill up with fuel.
- Close the filler cap.



WARNING

After fueling, tighten down the filler cap as securely as possible by hand.

Changing the Fuel Pickup Body

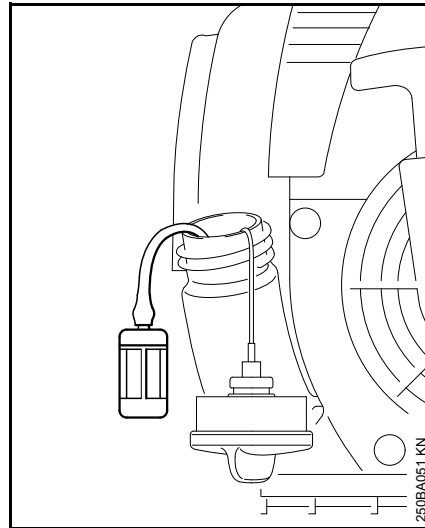

Change the fuel pickup body every year:

- Drain the fuel tank.
- Use a hook to pull the fuel pickup body out of the tank and take it off the hose.
- Push the new pickup body into the hose.
- Place the pickup body in the tank.

Fitting the Harness

The type and style of the harness depend on the market.

The use of the shoulder strap is described in the chapter on "Approved Combinations of Cutting Attachment, Deflector, Handle and Harness".

Shoulder strap

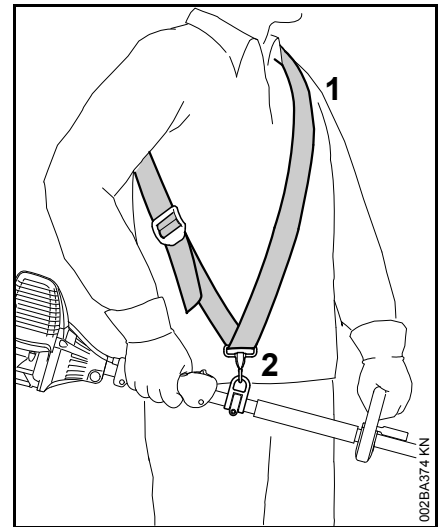

- Put on the shoulder strap (1).
- Adjust the length of the strap so that the carabiner (2) is about a hand's width below your right hip.
- Balance the brushcutter.

Full harness

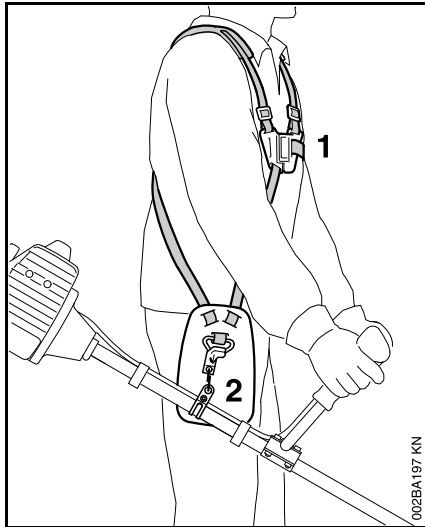

- Put on the full harness (1).
- Adjust the length of the strap so that the spring hook (2) is about a hand's width below your right hip.
- Balance the trimmer/brushcutter.

Attach the machine to the shoulder strap.

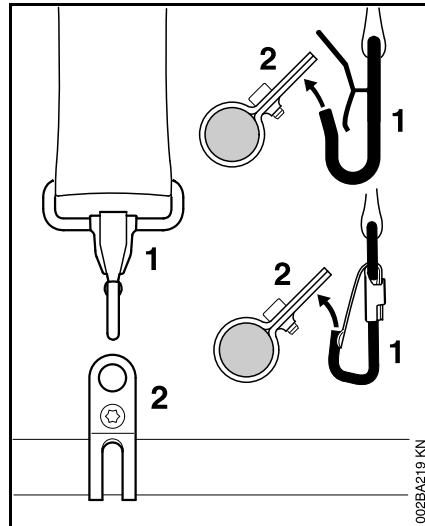

The type and style of the harness and carabiner (spring hook) depend on the market.

- Attach the carabiner (1) to the carrying ring (2) on the drive tube.

Detaching machine from shoulder strap

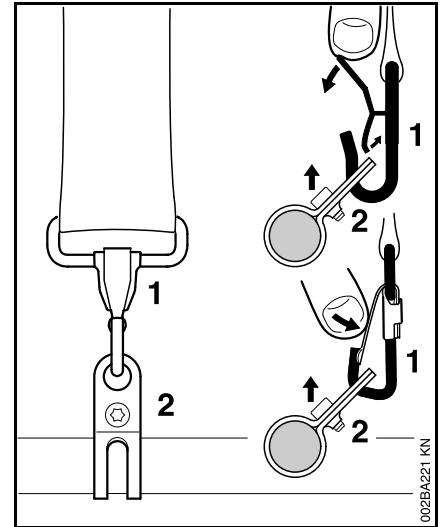

- Press down the bar on the carabiner (1) and pull the carrying ring (2) out of the carabiner.

Balancing the Trimmer/Brushcutter

Balancing the Machine

The unit is balanced differently depending on the cutting attachment used.

Proceed as follows until the conditions specified under "Floating positions" have been met:

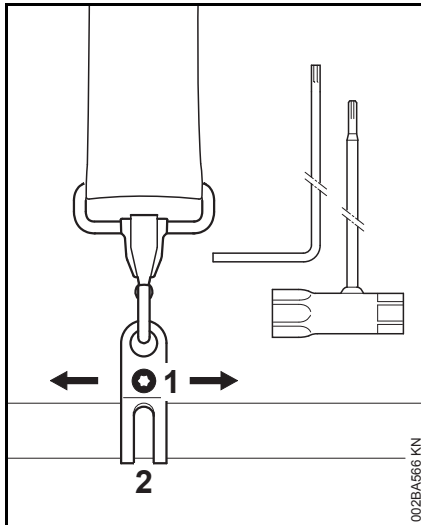

- Loosen the screw (1).
- Slide the carrying ring (2) along the drive tube.
- Tighten the screw moderately.
- Allow the unit to hang freely.
- Check the position obtained.

Floating Positions

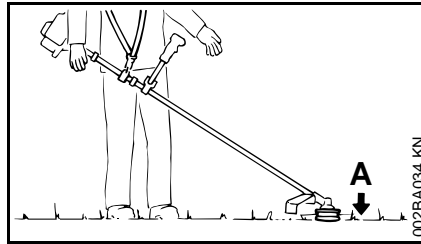

Mowing tools (A) such as mowing heads, grass cutting blades and brush knives

- should just touch the ground.

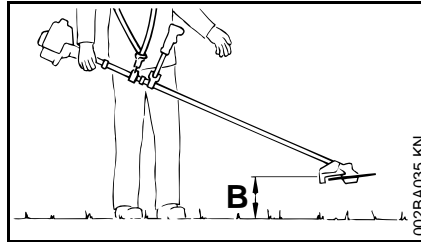

Circular saw blades (B)

- should "hover" about 20 cm (8 in) above the ground.

When the correct floating position has been reached:

- Tighten down the screw on the carrying ring firmly.

Starting / Stopping the Engine

Controls

Control handle on handlebar

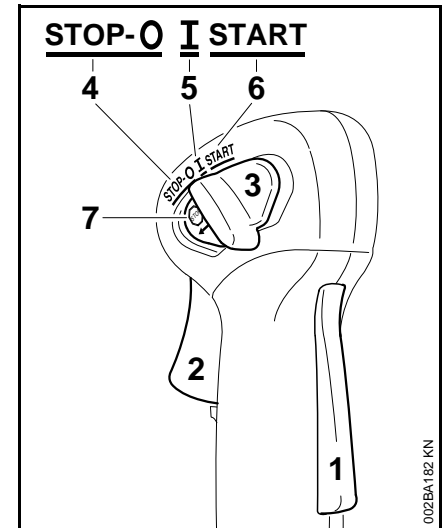

- 1 Throttle trigger lockout
- 2 Throttle trigger
- 3 Slide control

Control Handle on drive tube

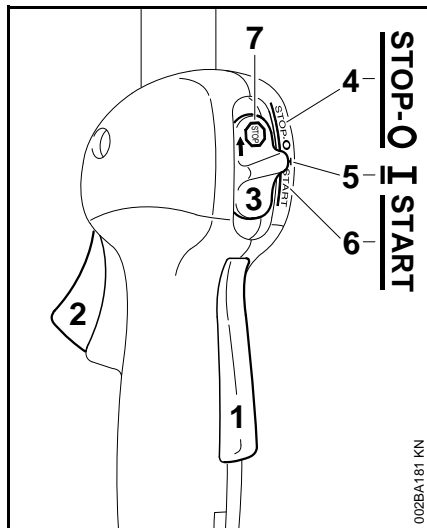



- 1 Throttle trigger lockout
- 2 Throttle trigger
- 3 Slide control

Positions of slide control

- 4 **STOP-0** – engine off – ignition is switched off
- 5 **I** – normal run position – the engine is running or can start
- 6 **START** – ignition is switched on – the engine can start



Symbol on slide control

- 7  – stop symbol and arrow. To stop the engine, push the slide control in the direction of the arrow on the stop symbol () to **STOP-0**.

Starting

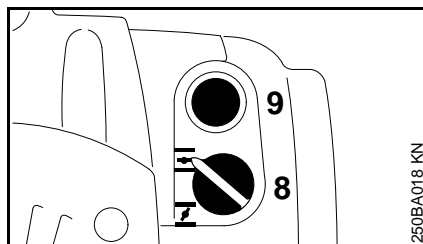
- Press down the trigger lockout lever and squeeze the throttle trigger
- and hold them in that position.
- Move the slide control to **START** and hold it there.
- Now release the throttle trigger, slide control and trigger lockout in that order. This is the **starting throttle position**.



- Set the choke knob (8):
 -  if the engine is cold
 -  for warm start – also use this position if the engine has been running but is still cold.
- Press the fuel pump bulb (9) at least five times – even if the bulb is filled with fuel.

Cranking

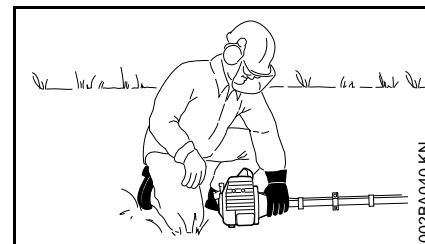
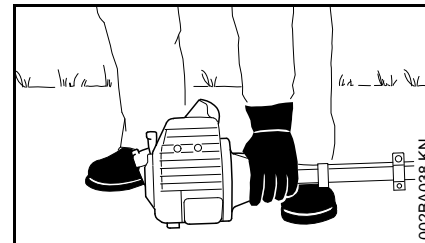

- If fitted: Remove the transport guard from the cutting attachment.
- Place the unit on the ground: It must rest securely on the engine support and the deflector. Check that the cutting attachment is not touching the ground or any other obstacles.
- Make sure you have a safe and secure footing.
- Hold the unit **firmly** on the ground with your left hand and press down – do not touch the throttle trigger or lockout lever – your thumb should be under the fan housing.



NOTICE

Do not stand or kneel on the drive tube.

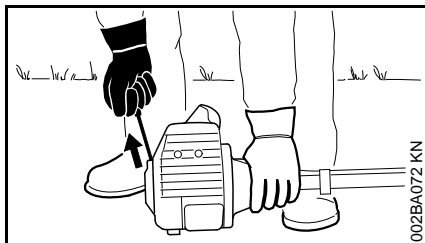

- Hold the starter grip with your right hand.
- Pull the starter grip slowly until you feel it engage and then give it a brisk strong pull.

NOTICE

Do not pull out the starter rope all the way – **it might otherwise break.**

- Do not let the starter grip snap back. Guide it slowly back into the housing so that the starter rope can rewind properly.
- Continue cranking.

When engine begins to fire

- Turn the choke knob to $\overline{\text{I}}$.
- Continue cranking until the engine runs.

As soon as the engine runs:

- Blip the throttle trigger **immediately**. The slide control moves to the normal run position **I** – and the engine settles down to idle speed.

WARNING

Make sure the carburetor is correctly adjusted. The cutting attachment must not rotate when the engine is idling.

The machine is now ready for operation.

Stopping the engine

- Push the slide control in the direction of the arrow on the stop symbol (STOP-0) to **STOP-0**.

At very low outside temperatures

As soon as the engine runs:

- Blip the throttle trigger **to disengage the starting throttle position**. The slide control moves to the normal run position **I** – and the engine settles down to idle speed.
- Open the throttle slightly.
- Warm up the engine for a short period.

If engine does not start

Choke knob

If you did not turn the choke knob to $\overline{\text{I}}$ quickly enough after the engine began to fire, the combustion chamber is flooded.

- Turn the choke knob to $\overline{\text{I}}$.
- Select the **starting throttle position**.
- Start the engine by pulling the starter rope briskly – 10 to 20 pulls may be necessary.

If the engine still does not start

- Push the slide control in the direction of the arrow on the stop symbol (STOP-0) to **STOP-0**.
- Remove the spark plug – see "Spark Plug".

- Dry the spark plug.
- Open the throttle wide.
- Crank the engine several times with the starter to clear the combustion chamber.
- Refit the spark plug – see "Spark Plug".
- Move the slide control to **START**.
- Set the choke knob to $\overline{\text{I}}$ – even if the engine is cold.
- Start the engine.

Throttle cable adjustment

- Check adjustment of throttle cable – see chapter on "Adjusting the Throttle Cable".

Fuel tank run until completely dry

- After refueling, press the fuel pump bulb at least five times – even if the bulb is filled with fuel.
- Set the choke knob to $\overline{\text{I}}$ if the engine is cold
- $\overline{\text{I}}$ for warm start – also use this position if the engine has been running but is still cold.
- $\overline{\text{I}}$ if the engine is hot
- Now start the engine – the procedure for starting a hot engine is the same as that for a cold engine.

Operating Instructions

During break-in period

A factory-new machine should not be run at high revs (full throttle off load) for the first three tank fillings. This avoids unnecessary high loads during the break-in period. As all moving parts have to bed in during the break-in period, the frictional resistances in the engine are greater during this period. The engine develops its maximum power after about 5 to 15 tank fillings.

During Operation

After a long period of full throttle operation, allow the engine to run for a short while at idle speed so that engine heat can be dissipated by the flow of cooling air. This protects engine-mounted components (ignition, carburetor) from thermal overload.

After Finishing Work

Storing for a short period: Wait for the engine to cool down. Empty the fuel tank and keep the machine in a dry place, well away from sources of ignition, until you need it again. For longer out-of-service periods – see "Storing the Machine".

Cleaning the Air Filter

If there is a noticeable loss of engine power

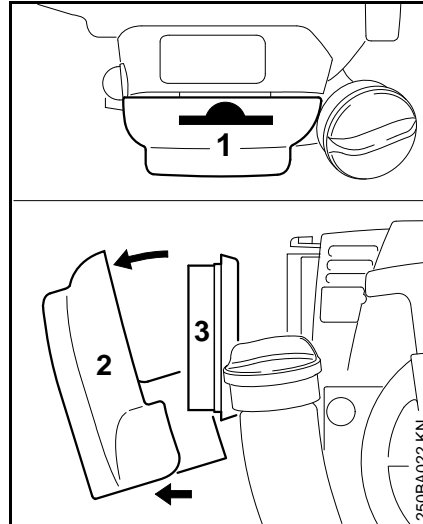

- Turn the choke knob to **I**.
- Press in the tab (1) and remove the filter cover (2).
- Clean away loose dirt from around the filter (3) and inside the filter cover.
- Remove and check the filter element – replace it if it is dirty or damaged.
- Install the filter element in the filter cover.
- Refit the filter cover.

Adjusting the Carburetor

General Information

The carburetor comes from the factory with a standard setting.

This setting provides an optimum fuel-air mixture under most operating conditions.

Preparations

- Shut off the engine.
- Mounting the Cutting Attachment
- Check the air filter and clean or replace if necessary.
- Check that the throttle cable is properly adjusted – readjust if necessary – see chapter on "Adjusting the Throttle Cable".

Different Standard Settings

Different carburetors are installed at the factory. A different standard setting is necessary for each of these carburetors.

Standard setting A

- High speed screw (H) = 3/4
- Low speed screw (L) = 1

Standard setting B

- High speed screw (H) = 3/4
- Low speed screw (L) = 3/4

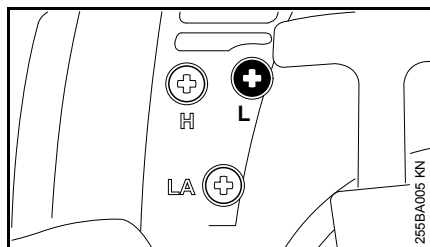

- Determine the standard setting as follows: Turn the low speed screw (L) carefully clockwise as far as stop, then turn it counterclockwise.

Is range of adjustment more than 1 turn?

- Continue with **"Standard setting A"**

Is range of adjustment less than 1 turn?

- Continue with **"Standard setting B"**

Standard setting A

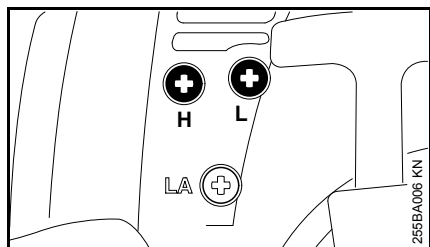

- Turn high speed screw (H) counterclockwise as far as stop (no more than 3/4 turn).
- Turn the low speed screw (L) carefully clockwise until it is against its seat, then turn it back 1 full turn

Standard setting B

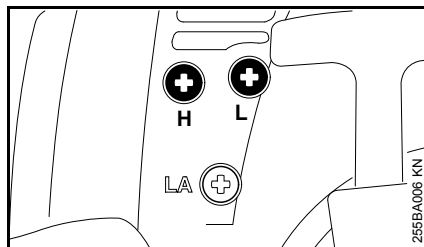

- Turn high speed screw (H) counterclockwise as far as stop (no more than 3/4 turn).
- Turn the low speed screw (L) carefully clockwise as far as stop, then turn it back 3/4 turn.

Adjusting Idle Speed

- Carry out the standard setting.
- Start and warm up the engine.

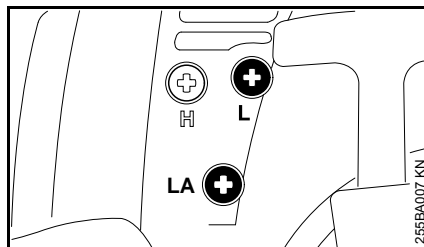

Engine stops while idling

- Turn the idle speed screw (LA) clockwise until the engine runs smoothly – the cutting attachment must not rotate.

Cutting attachment rotates when engine is idling

- Turn the idle speed screw (LA) counterclockwise until the cutting attachment stops moving and then turn the screw another 1/2 to 1 full turn in the same direction.

! WARNING

If the cutting attachment continues to rotate when the engine is idling, have your machine checked and repaired by your servicing dealer.

Erratic idling behavior, poor acceleration (despite correction to setting of LA screw).

Idle setting is too lean

- Turn the low speed screw (L) counterclockwise, no further than stop, until the engine runs and accelerates smoothly.

Erratic idling behavior

Idle setting is too rich

- Turn the low speed screw (L) clockwise, no further than stop, until the engine runs and accelerates smoothly.

It is usually necessary to change the setting of the idle speed screw (LA) after every correction to the low speed screw (L).

Fine Tuning for Operation at High Altitude

A slight correction of the setting may be necessary if engine does not run satisfactorily:

- Carry out the standard setting.
- Warm up the engine.
- Turn high speed screw (H) slightly clockwise (leaner) – no further than stop.

 **NOTICE**

After returning from high altitude, reset the carburetor to the standard setting.

If the setting is too lean there is a risk of engine damage due to insufficient lubrication and overheating.

Spark Plug

- If the engine is down on power, difficult to start or runs poorly at idle speed, first check the spark plug.
- Fit a new spark plug after about 100 operating hours – or sooner if the electrodes are badly eroded. Install only suppressed spark plugs of the type approved by STIHL – see "Specifications".

Removing the Spark Plug

- Turn off the engine.

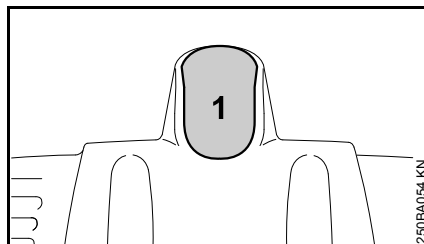

- Pull off the spark plug boot (1).
- Unscrew the spark plug.

Checking the spark plug

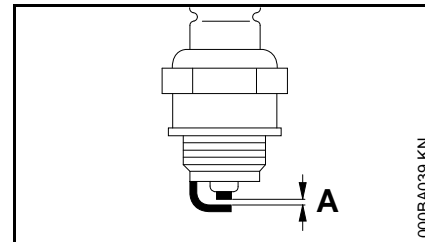

- Clean dirty spark plug.
- Check electrode gap (A) and readjust if necessary – see "Specifications".
- Rectify the problems which have caused fouling of the spark plug.

Possible causes are:

- Too much oil in fuel mix.
- Dirty air filter.
- Unfavorable running conditions.

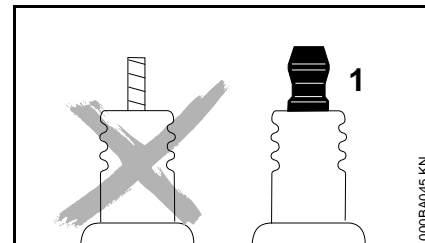

 **WARNING**

If the spark plug comes with a detachable adapter nut (1), screw the adapter onto the thread and tighten it down **firmly** to reduce the **risk of arcing and fire**.

Installing the Spark Plug

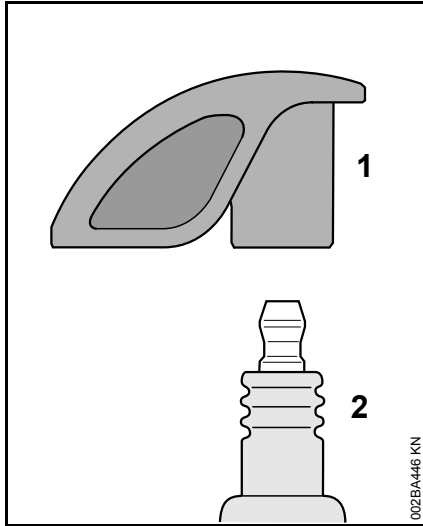

- Screw the spark plug (2) into the cylinder and fit the boot (1) (press it down firmly).

Engine Running Behavior

If engine running behavior is unsatisfactory even though the air filter is clean and the carburetor and throttle cable are properly adjusted, the cause may be the muffler.

Have the muffler checked by a servicing dealer for contamination (carbonization).

STIHL recommends that you have servicing and repair work carried out exclusively by an authorized STIHL servicing dealer.

Lubricating the Gearbox

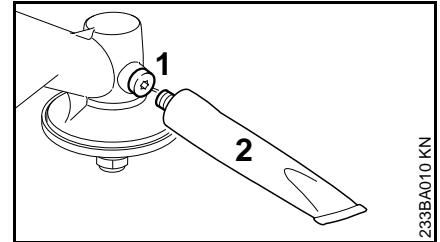

- Check the grease level regularly – about every 25 hours of operation.
- Unscrew the filler plug (1). If no grease can be seen on the inside of the filler plug, screw the tube (2) of STIHL gear lubricant for brushcutters (special accessory) into the filler hole.
- Squeeze up to 5 g grease into the gearbox.

NOTICE

Do not completely fill the gearbox with grease.

- Remove the tube of grease (2).
- Refit the filler plug (1) and tighten it down firmly.

Replacing the Starter Rope and Rewind Spring

Removing the Fan Housing

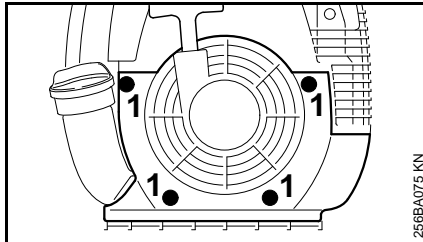

- Take out the screws (1).
- Remove the fan housing.

Replacing the Starter Rope

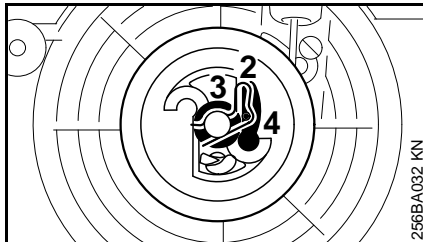

- Remove the spring clip (2).
- Carefully remove the rope rotor with washer (3) and pawl (4).

WARNING

The rewind spring may pop out and uncoil during this operation – take care to avoid the risk of injury.

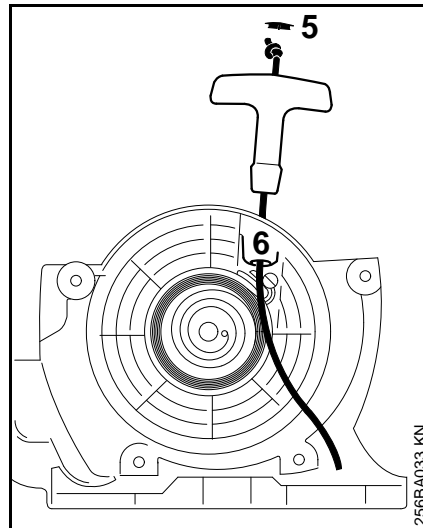

- Pry the cap (5) out of the grip.
- Remove the remaining rope from the rotor and starter grip.
- Tie a simple overhand knot in the new rope and then thread it through the top of the grip and the rope bushing (6).
- Refit the cap in the grip.

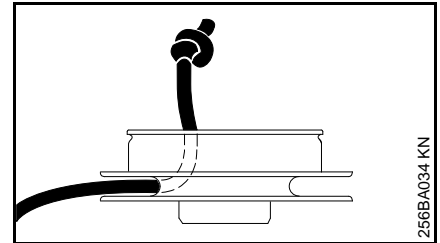

- Pull the rope through the rotor and secure it with a simple overhand knot.
- Coat rope rotor bearing bore with non-resinous oil – see "Special Accessories".
- Slip the rotor over the starter post – turn it back and forth to engage the anchor loop of the rewind spring.

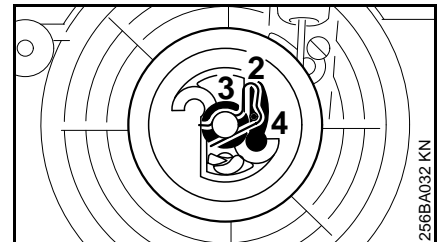

- Fit the pawl (4).
- Fit the washer (3).
- Push the spring clip (2) into position – it must point counterclockwise as shown and engage the pawl's peg.

Tensioning the Rewind Spring

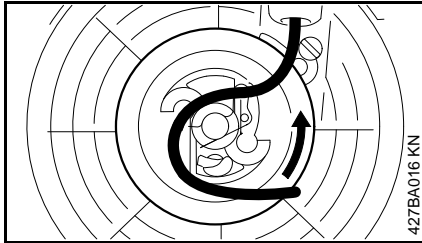

- Make a loop in the unwound starter rope and use it to turn the rope rotor six full revolutions counterclockwise.
- Hold the rotor steady.
- Pull out and straighten the twisted rope.
- Let go of the rotor.
- Release the rope slowly so that it winds onto the rotor.

The starter grip must sit firmly in the rope bushing. If the grip droops to one side: Add one more turn on the rope rotor to increase spring tension.



NOTICE

When the starter rope is fully extended it must still be possible to rotate the rotor another one and a half turns. If this is not the case, the spring is overtensioned and could break.

- Take one turn of the rope off the rotor.
- Fit the fan housing.

Replacing a Broken Rewind Spring

- Remove the rope rotor as described in "Replacing the Starter Rope".



WARNING

The bits of the spring may still be under tension and could fly apart when you remove the rope rotor and spring housing. To **reduce the risk of injury**, wear face protection and work gloves.

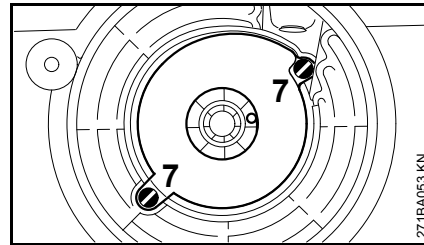

- Take out the screws (7).
- Remove the spring housing and pieces of spring.
- Lubricate the new, ready-to-fit replacement spring in the new spring housing with a few drops of resin-free oil – see "Special Accessories".
- Place the replacement spring with spring housing in position – bottom plate facing up.

If the spring pops out of the housing during installation: Refit it clockwise, starting outside and working inwards.

- Fit the screws.
- Refit the rope rotor as described in "Replacing the Starter Rope".

- Tension the rewind spring.
- Fit the fan housing.

Storing the Machine

For periods of 3 months or longer

- Drain and clean the fuel tank in a well ventilated area.
- Dispose of fuel properly in accordance with local environmental requirements.
- Run the engine until the carburetor is dry – this helps prevent the carburetor diaphragms sticking together.
- Remove, clean and inspect the cutting attachment.
- Thoroughly clean the machine – pay special attention to the cylinder fins and air filter.
- Store the machine in a dry and secure location – out of the reach of children and other unauthorized persons.

Sharpening Metal Cutting Blades

- Use a sharpening file (special accessory) to sharpen dull cutting attachments. In case of more serious wear or nicks: Resharpener with a grinder or have the work done by a dealer – STIHL recommends a STIHL servicing dealer.
- Resharpener frequently, take away as little material as possible: two or three strokes of the file are usually enough.

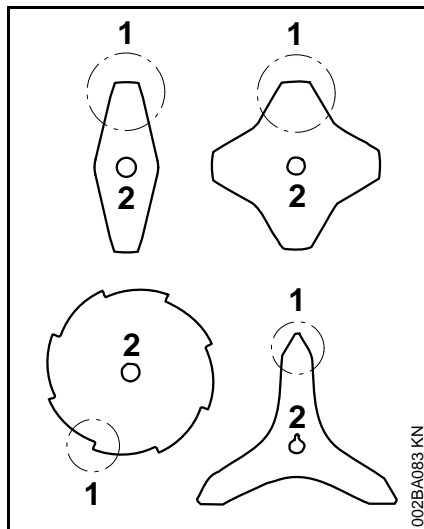

- Resharpener the cutters (1) uniformly – do not alter the contour or the parent blade (2) in any way.

See cutting attachment packaging for additional sharpening instructions.

Balancing

- After resharpening about 5 times, check the cutting attachment for out-of-balance on a STIHL balancer (special accessory) or have it checked by a dealer and re-balanced as necessary – STIHL recommends a STIHL servicing dealer.

Replacing Nylon Line

Always check the mowing head for signs of wear before replacing the nylon line.

WARNING

If there are signs of serious wear, replace the complete mowing head.

The nylon mowing line is referred to as "nylon line" or "line" in the following.

The mowing head is supplied with illustrated instructions for replacing the nylon line. You should therefore keep the instructions for the mowing head in a safe place.

Adjustment of the nylon line is described below.

Preparing the machine for replacing nylon line

- Shut off the engine.

WARNING

To reduce the risk of injury, always shut off the engine before replacing nylon line.

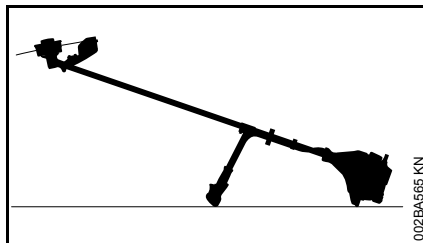

- Put the power tool on the ground with the mowing head facing up.
- If necessary, remove the mowing head.

Adjusting nylon line

SuperCut mowing head

Fresh line is advanced automatically if the remaining line is **at least 6 cm (2 1/2 in)** long. The blade on the deflector trims overlong lines to the correct length.

AutoCut mowing head

- With the engine running, hold the rotating mowing head above the grass surface.
- Tap it on the ground once – fresh line is advanced and the blade on the deflector trims it to the right length.

Fresh line is advanced every time the mowing head is tapped on the ground. For this reason observe the mowing head's cutting performance during operation. If the mowing head is tapped on the ground too often, the line limiter blade will unnecessarily cut off unused lengths of nylon line.

Line feed operates only if both lines are still at least 2.5 cm (1 in) long.

TrimCut mowing head

- Shut off the engine.

WARNING

To reduce the risk of injury, always shut off the engine before adjusting the nylon line by hand.

- Pull the spool up – rotate it about 1/6 turn counterclockwise until it engages – and allow it to spring back.
- Pull ends of the lines outward.

Repeat the above procedure as necessary until both lines are about 13 cm (5 in) long.

Rotating the spool from one stop to the next advances about 4 cm (1 1/2 in) of fresh line.

Fitting Fresh Nylon Line

PolyCut Mowing Head

A length of nylon line can be fitted to the PolyCut in place of the cutting blades.

- Shut off the engine.

WARNING

To reduce the risk of injury, always shut off the engine before installing new blades.

- Fit nylon line in mowing head as described in the instructions supplied.

Replacing the Cutting Blade

PolyCut Mowing Head

Always check the mowing head for signs of wear before installing new cutting blades.

WARNING

If there are signs of serious wear, replace the complete mowing head.

The thermoplastic cutting blades are referred to as "blades" in the following.

The mowing head is supplied with illustrated instructions for replacing the blades. You should therefore keep the instructions for the mowing head in a safe place.

Preparing the machine for installation of new blades

- Shut off the engine.

WARNING

To reduce the risk of injury, always shut off the engine before installing new blades.

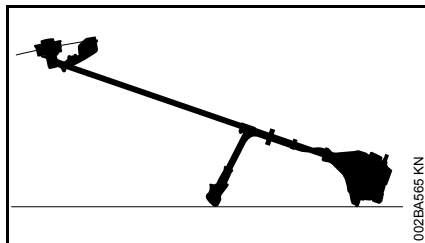

- Put the power tool on the ground with the mowing head facing up.
- Remove the mowing head.
- Replace blades as shown in the illustrated instructions.
- Mount the mowing head on the machine.

Maintenance and Care

The following intervals apply to normal operating conditions only. If your daily working time is longer or operating conditions are difficult (very dusty work area, etc.), shorten the specified intervals accordingly.		before starting work	after finishing work or daily	after each refueling stop	weekly	monthly	every 12 months	if problem	if damaged	if required
Complete machine	Visual inspection (condition, leaks)	X		X						
	Clean		X							
Control handle	Check operation	X		X						
Air filter	Clean							X		X
	Replace								X	
Pickup body in fuel tank	Check							X		
	Replace					X			X	X
Fuel tank	Clean					X		X		X
Carburetor	Check idle adjustment – the cutting attachment must not turn	X		X						
	Readjust idle									X
Spark plug	Readjust electrode gap							X		
	Replace after every 100 operating hours									
Cooling inlets	Visual inspection		X							
	Clean									X
All accessible screws and nuts (not adjusting screws)	Retighten									X
Antivibration elements	Check	X						X		X
	Replace ¹⁾								X	
Cutting attachment	Visual inspection	X		X						
	Replace								X	
	Check tightness	X		X						

The following intervals apply to normal operating conditions only. If your daily working time is longer or operating conditions are difficult (very dusty work area, etc.), shorten the specified intervals accordingly.		before starting work	after finishing work or daily	after each refueling stop	weekly	monthly	every 12 months	if problem	if damaged	if required
Metal cutting attachment	Sharpen	X								X
Gearbox lubrication	Check				X			X		X
	Replenish									X
Safety labels	Replace								X	

¹⁾ STIHL recommends that this work be done by a STIHL servicing dealer

Main Parts

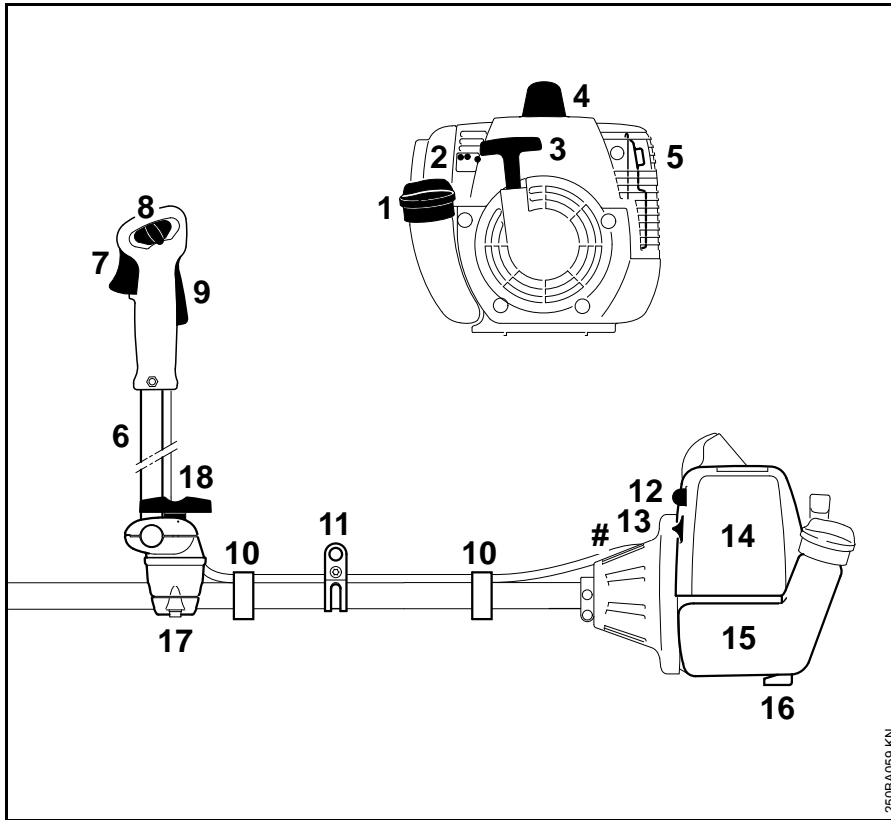

- 1 Fuel filler cap
- 2 Carburetor adjusting screws
- 3 Starter grip
- 4 Spark plug boot
- 5 Muffler
- 6 Bike handle (handlebar)
- 7 Throttle trigger
- 8 Slide control
- 9 Throttle trigger lockout
- 10 Throttle cable retainer
- 11 Carrying ring
- 12 Fuel pump
- 13 Choke knob
- 14 Air filter cover
- 15 Fuel tank
- 16 Machine support
- 17 Handle support
- 18 Wing screw
- # Serial number

250BA059 KN

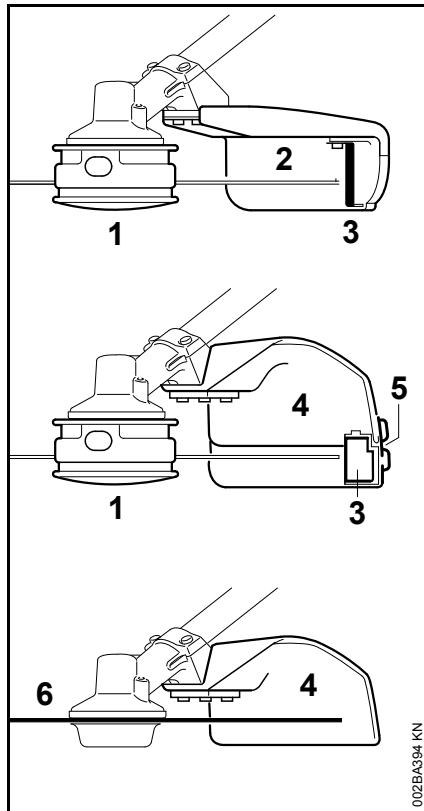

- 1 Mowing head
- 2 Deflector (only for mowing heads and grass cutting blades)
- 3 Blade
- 4 Deflector (for all mowing tools)
- 5 Skirt
- 6 Metal mowing tool

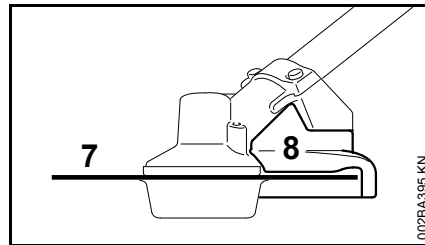

- 7 Circular saw blade
- 8 Limit stop for circular saw blades only

Specifications

Engine

Single cylinder two-stroke engine

FS 120

Displacement:	30.8 cm ³
Bore:	35 mm
Stroke:	32 mm
Engine power to ISO 8893:	1.3 kW (1.8 HP) at 9,000 rpm
Idle speed:	2,800 rpm
Cut-off speed (rated):	12,300 rpm
Max. output shaft speed (cutting attachment):	8,790 rpm

FS 250

Displacement:	40.2 cm ³
Bore:	40 mm
Stroke:	32 mm
Engine power to ISO 8893:	1.6 kW (2.2 HP) at 9,000 rpm
Idle speed:	2,800 rpm
Cut-off speed (rated):	12,300 rpm
Max. output shaft speed (cutting attachment):	8,790 rpm

Ignition System

Electronic magneto ignition

Spark plug (resistor type):	Bosch WSR 6 F, NGK BPMPR 7 A
Electrode gap:	0.5 mm

Fuel System

All position diaphragm carburetor with integral fuel pump

Fuel tank capacity: 0.64 L

Weight

dry, without cutting attachment and deflector

FS 120: 6.3 kg

FS 250: 6.3 kg

Overall length

without cutting attachment

FS 120: 1765 mm

FS 250: 1770 mm

Noise and Vibration Data

For further details on compliance with Vibration Directive 2002/44/EC see www.stihl.com/vib.

Sound pressure level L_{peq} to ISO 22868

with mowing head

FS 120: 98 dB(A)

FS 250: 99 dB(A)

with metal mowing attachment

FS 120: 97 dB(A)

FS 250: 98 dB(A)

Sound power level L_{weq} to ISO 22868

with mowing head

FS 120: 108 dB(A)

FS 250: 106 dB(A)

with metal mowing attachment

FS 120: 107 dB(A)

FS 250: 107 dB(A)

Vibration measurement $a_{hv,eq}$ to ISO 22867

with mowing head

	Handle, left	Handle, right
FS 120:	4.9 m/s ²	3.5 m/s ²
FS 250:	6.4 m/s ²	3.4 m/s ²

with metal mowing attachment

	Handle, left	Handle, right
FS 120:	4.9 m/s ²	2.8 m/s ²
FS 250:	5.9 m/s ²	3.0 m/s ²

The K-factor in accordance with Directive 2006/42/EC is 2.5 dB(A) for the sound pressure level and sound power level; the K-factor in accordance with Directive 2006/42/EC is 2.0 m/s² for the vibration measurement.

Special Accessories**Cutting Attachments****Mowing heads**

1 STIHL SuperCut 20-2

2 STIHL AutoCut 25-2

3 STIHL AutoCut 30-2

4 STIHL TrimCut 31-2

5 STIHL FixCut 25-2

6 STIHL PolyCut 20-3

Metal cutting attachments

7 Grass cutting blade 230-2

8 Grass cutting blade 230-4

9 Grass cutting blade 230-8

10 Grass cutting blade 250-40 Spezial

11 Brush knife 250-3

12 Scratcher tooth circular saw blade 200

13 Chisel tooth circular saw blade 200

**WARNING**

Use cutting attachments only as specified in the chapter on "Approved Combinations of Cutting Attachment, Deflector, Handle and Harness".

Special accessories for cutting attachments

- Nylon line for mowing heads 1 to 6
- Prewound spool with nylon line for 1 to 4
- Thermoplastic blades, pack of 12; for 6
- Transport guards for 7 to 13

Sharpening aids for metal cutting attachments

- Flat sharpening files for 7 to 9, 11 and 12
- File holder with round file, for 13
- Saw set, for 13
- STIHL balancer for 7 to 13
- Sharpening templates (metal or cardboard), for 11

Mounting hardware for metal cutting attachments

- Thrust washer
- Rider plate
- Nut

Other special accessories

- Safety glasses
- Shoulder strap
- Full harness
- Combination wrench
- Locking pin
- Carburetor screwdriver
- STIHL ElastoStart (starter rope with grip)
- STIHL gear lubricant for brushcutters
- STIHL filler nozzle for fuels
- Special resin-free lubricating oil

Contact your STIHL dealer for more information on these and other special accessories.

Maintenance and Repairs

Users of this machine may only carry out the maintenance and service work described in this user manual. All other repairs must be carried out by a servicing dealer.

STIHL recommends that you have servicing and repair work carried out exclusively by an authorized STIHL servicing dealer. STIHL dealers are regularly given the opportunity to attend training courses and are supplied with the necessary technical information.

When repairing the machine, only use replacement parts which have been approved by STIHL for this power tool or are technically identical. Only use high-quality replacement parts in order to avoid the risk of accidents and damage to the machine.

STIHL recommends the use of original STIHL replacement parts.

Original STIHL parts can be identified by the STIHL part number, the **STIHL** logo and the STIHL parts symbol  (the symbol may appear alone on small parts).

Disposal

Observe all country-specific waste disposal rules and regulations.

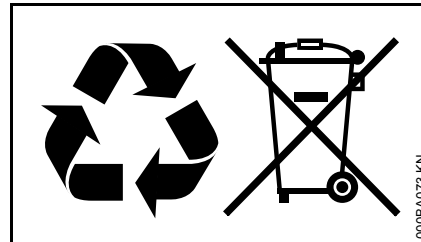

STIHL products must not be thrown in the garbage can. Take the product, accessories and packaging to an approved disposal site for environment-friendly recycling.

Contact your STIHL servicing dealer for the latest information on waste disposal.

EC Declaration of Conformity

ANDREAS STIHL AG & Co. KG
Badstr. 115
D-71336 Waiblingen

confirms that the product described below

Category:	Trimmer
Make:	STIHL
Model:	FS 120 FS 250
Serial identification:	4134
Displacement	
FS 120:	30.8 cm ³
FS 250:	40.2 cm ³

conforms to the specifications of Directives 2006/42/EC, 2004/108/EC and 2000/14/EC and has been developed and manufactured in compliance with the following standards:

EN ISO 11806, EN 55012,
EN 61000-6-1

The measured and guaranteed sound power levels were determined according to Directive 2000/14/EC, Annex V, using the ISO 10884 standard.

Measured sound power level

FS 120:	111 dB(A)
FS 250:	112 dB(A)

Guaranteed sound power level

FS 120:	113 dB(A)
FS 250:	114 dB(A)

Technical documents deposited at:

FS 120, FS 250

ANDREAS STIHL AG & Co. KG
Produktzulassung (Product Licensing)

The year of manufacture and serial number are applied to the product.

Done at Waiblingen, 01.10.2012

ANDREAS STIHL AG & Co. KG



Thomas Elsner

Director Group Product Management



Quality Certification



All STIHL products comply with the highest quality standards.

An independent organization has certified that all products manufactured by STIHL meet the strict requirements of the ISO 9001 standard for quality management systems in terms of product development, materials purchasing, production, assembly, documentation and customer service.

0458-250-8321-D

AUS



www.stihl.com



0458-250-8321-D